

User Guide for 4 axis TB6560 driver board

เป็นสินค้าจากประเทศจีน ที่มีจุดเด่นของ DRIVER BOARD ของ Toshiba TB6560AHQ chip ตามรายละเอียด

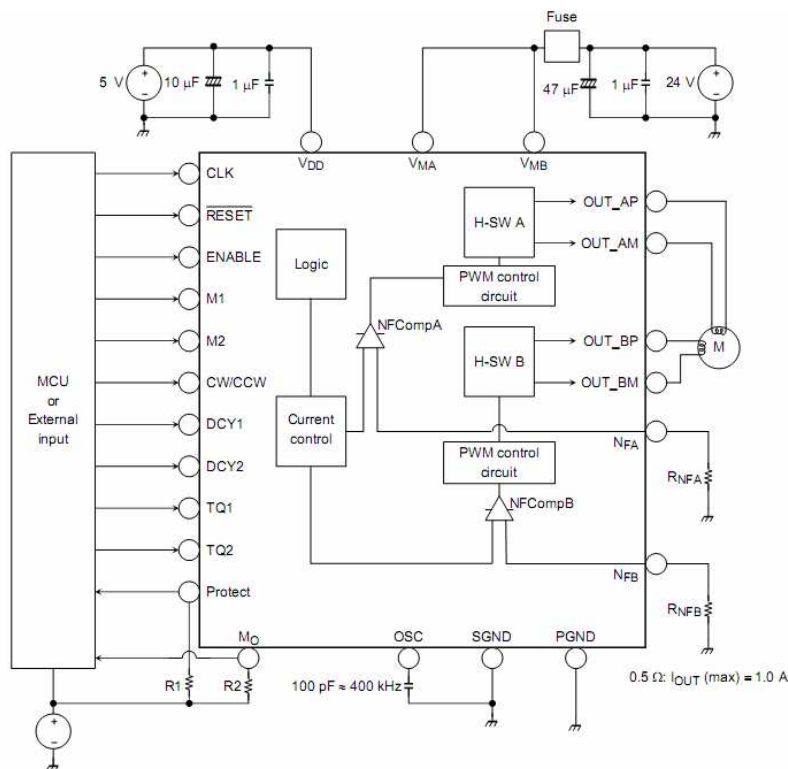

Block Diagram Toshiba TB6560AHQ chip

Product Features:

1. **Toshiba TB6560AHQ chip** - High power, maximum 3A (peak value 3.5A) drive current chipset !
2. **Micorstep** 1-1/16 micro step setting - Higher accuracy and smoother operation than standard 1, 1/2 step!
3. **current settings** Adjustable drive current settings for each axis - 25%,50%,75%,100% of full current can be set for different stepper motors
4. **Overload** over-current and over-temperature safety - Full protection for your computer and peripheral equipment !
5. **On board current switching** - Power output can be set according to specific user requirement !
6. **Full closed-type optical isolation** to protect the user's computer and equipment
7. **Relay spindle interface-Outputs** Max. 36V 7.5A for spindle motors or coolant pump (only one device can be powered by this output!)
8. **4channel inputs interface** Can be used for XYZ limit and emergency stop !(Input 1,2,3,4)
9. **Professional design** Two stage signal processing with super anti-jamming !
10. **Bipolar constant current** chopper drive with non-resonant region - Controls motors smoothly through range without creep effect !
11. **Universal architecture** Supports most parallel software MACH3,KCAM4,EMC2 etc!

* Important Notes:

Power supply DC 12-36V (not included)

*Voltage Selection:

12-16V DC power supply for Nema 17 stepper motors
 16-24V DC power supply for Nema 23 stepper motors
 24-36V DC power supply for Nema 34 stepper motors
 (High voltage will burn up the chips or stepper motors!!!)

***Ampertage Selection:**

Output current of the power supply can be calculated by the following expressions:

Output current = Rated current of your stepper motors * quantity + 2A

(For example, if you want to drive 3 * 3A Nema 23 stepper motors, theoretically 24V 11A DC power supply is recommended, but higher power such as 24V 15A also will be good.

If you are not sure about the selection of power supply, please feel free to contact us for help)

The power output of 12V shall be applied to the radiator fan of 12V

Driver output compatible with 2 or 4 phase, 4,6 or 8 lead stepper motors, 3A max.

Voltage regulated spindle speed controlled by parallel interface as function of supply voltage.

Wiring Diagram:

The diagram shows five wiring configurations for stepper motors:

- 4 Lead coils:** Shows two coils for phase A (A+, A-) and two for phase B (B+, B-).
- 6 Leads High Torque:** Shows three leads for phase A (A+, NC, A-) and three for phase B (B+, NC, B-).
- 6 Lead High Speed:** Shows three leads for phase A (A+, A-, NC) and three for phase B (B+, B-, NC).
- 8 Leads Series - wound High Torque:** Shows four leads for phase A (+A, -A) and four for phase B (+B, -B).
- 8 Leads Shunt - wound High Speed:** Shows four leads for phase A (+A, -A) and four for phase B (+B, -B).

Below the diagrams is a graph of TORQUE vs SPEED. The graph shows three curves: BIPOLAR SERIES (highest torque), BIPOLAR PARALLEL (middle torque), and UNIPOLAR & HALF COIL (lowest torque).

Serial & parallel Wiring Diagram For select Speed & Torque

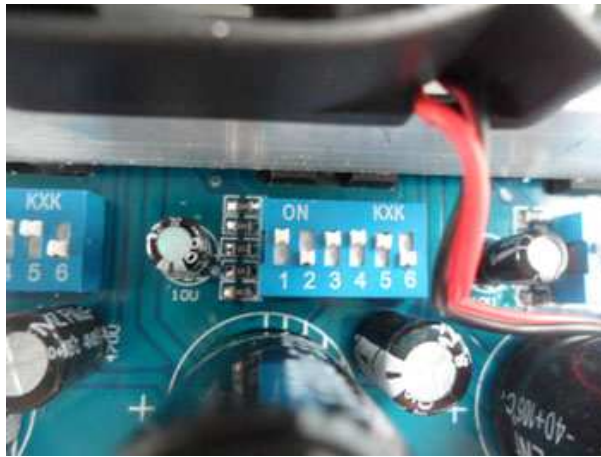

Dip Switch

Dip Switch settings:

Current Setting	1	2	Decay Mode Settings	3	4	MicroStep Settings	5	6
100%	ON	ON	FAST	ON	ON	1	ON	ON
75%	ON	OFF	25%	ON	OFF	1/2	ON	OFF
50%	OFF	ON	50%	OFF	ON	1/8	OFF	OFF
25%	OFF	OFF	SLOW	OFF	OFF	1/16	OFF	ON

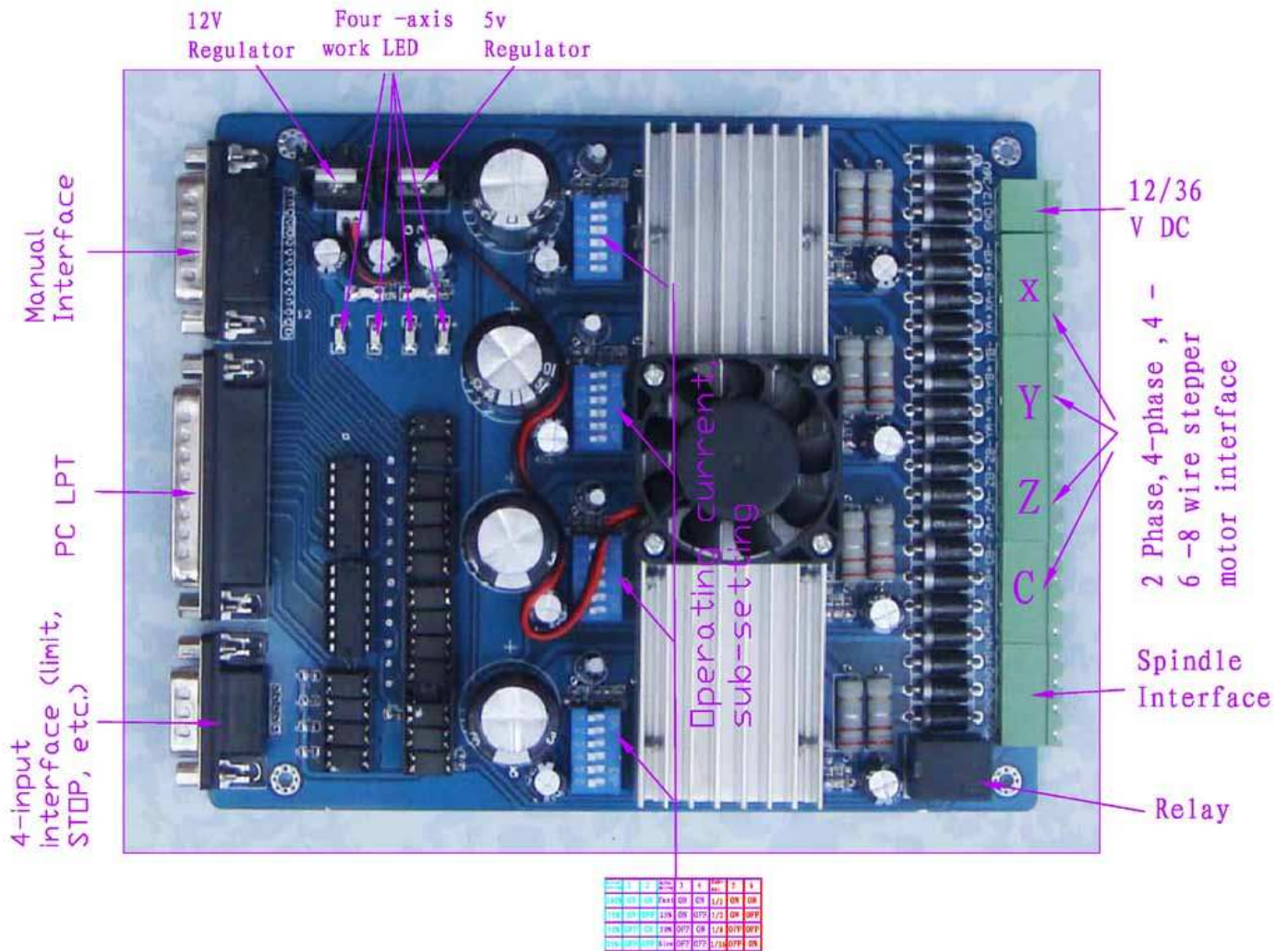

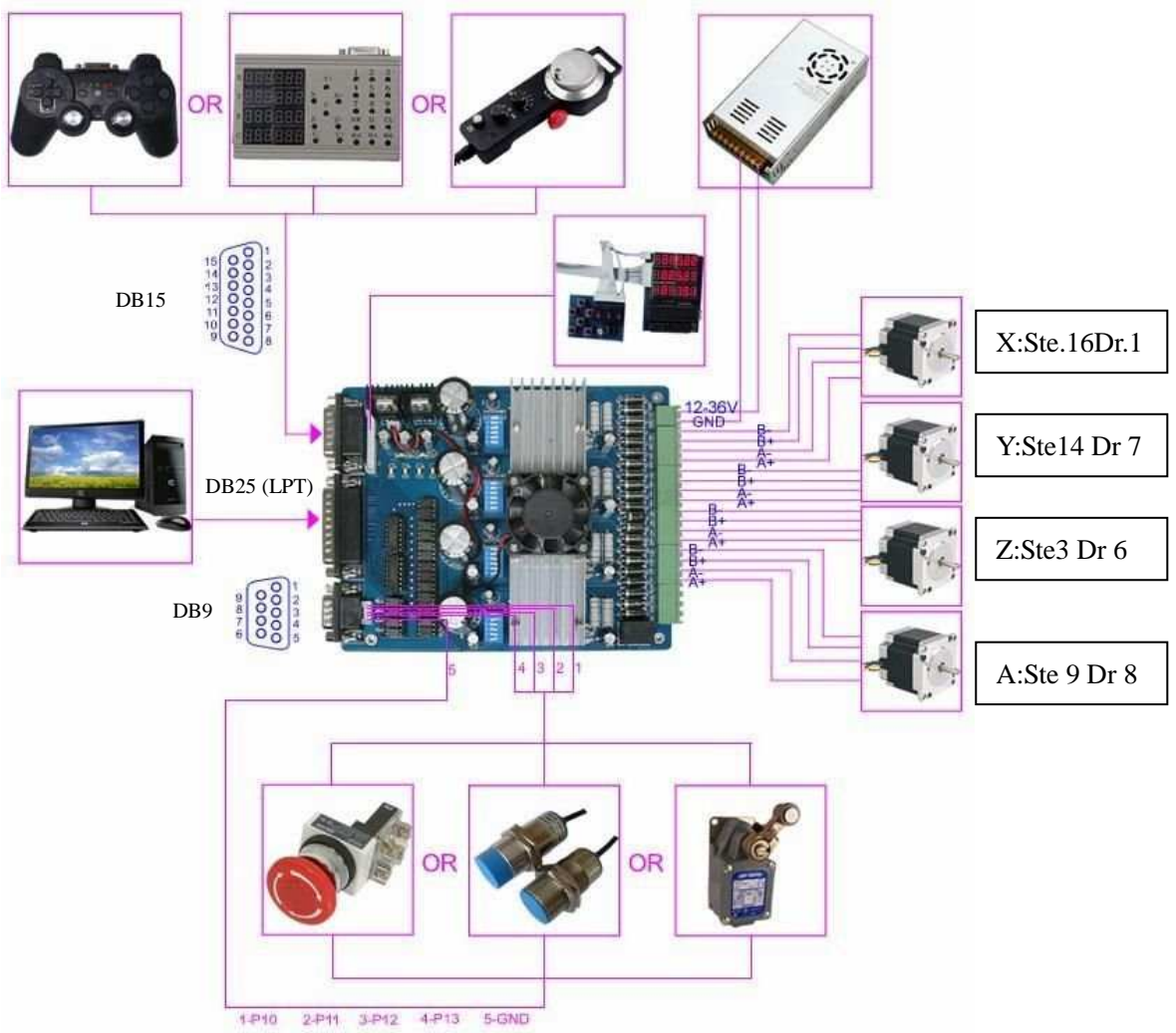

DB9 Connection Input	DB9	DB25 From Computer(LPT)	
	pin 1	pin 10	Limit & Home X
	pin 2	pin 11	Limit & Home Y
	pin 3	pin 12	Limit & Home Z
	pin 4	pin 13	E-Stop
	Pin 5-9	Ground	

The definition of 1-PIN 25 of Parallel Interface:(LPT)

PIN 2	PIN 4	PIN 1	PIN 16	PIN 17	PIN 7	PIN 14	PIN 5	PIN 6	PIN 3	PIN 5	PIN 8	PIN 9
Spindle motor	X Enable	X Dir	X Step	Y Enable	Y Dir	Y Step	Z Enable	Z Dir	Z Step	A Enable	A Dir	A step

The definition of DB9 4 channel inputs interface:

Pin 1	Pin 2	Pin 3	Pin 4	Pin 5	Pin 6	Pin 7	Pin 8	Pin 9
X Limit	Y Limit	Z Limit	STOP	Empty	GND	GND	GND	GND
P10	P11	P12	P13					

The definition of 1-PIN15 of Manual Interface:

Pin 1	Pin 2	Pin 3	Pin 4	Pin 5	Pin 6	Pin 7	Pin 8	Pin 9	Pin 10	Pin 11	Pin 12	Pin 13	Pin 14	Pin 15
Z/C Enable	C Step	Z Step	X Dir	X Enable	Y Enable	Y Dir	Z Dir	C Dir	Spindle motor	Y Step	X Step	STOP	GND	5V/vdd

Configuration Output Step & Dir X,Y ,Z,A

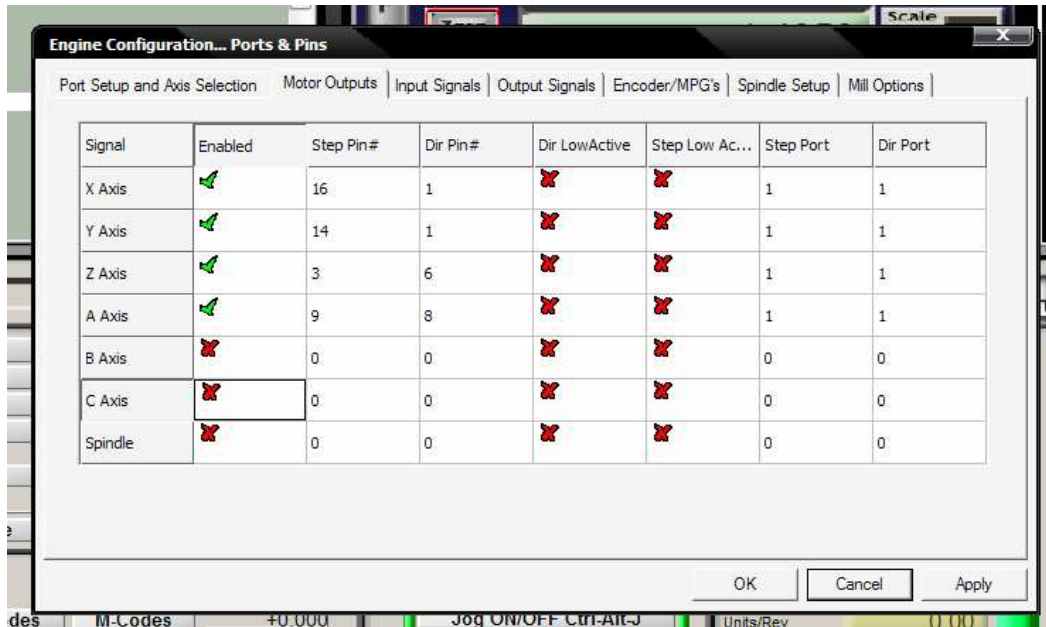

Configuration Output Enable 1-4(X,Y ,Z,A) pin 4,17,5,5 & Output#1 pin 2 For Spindle Motor (M3)

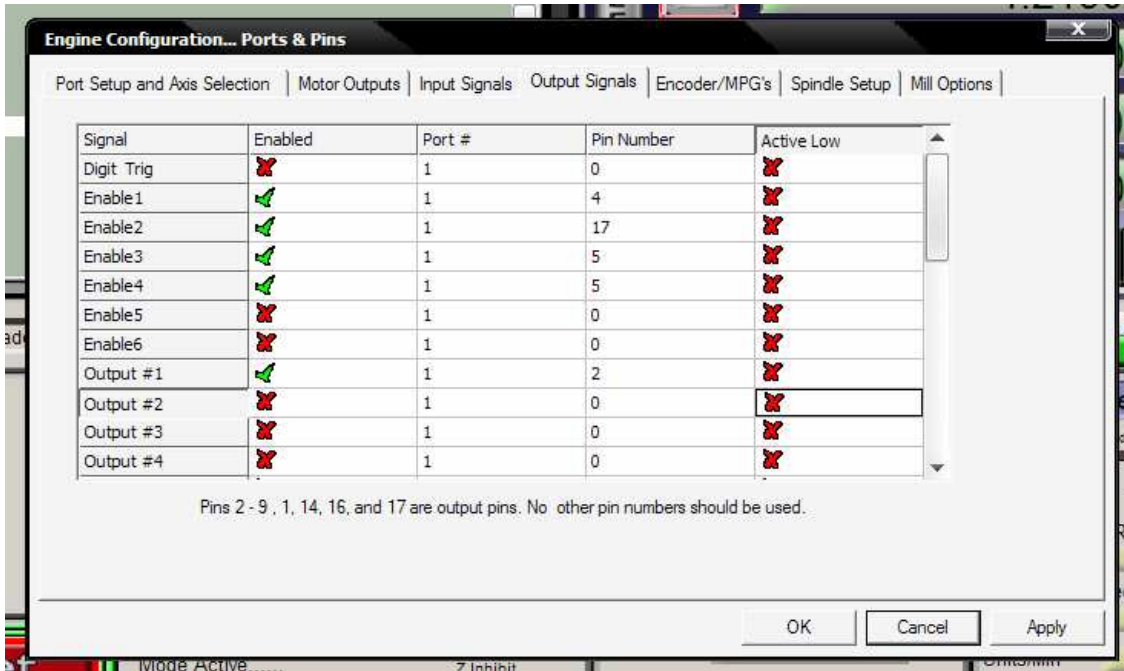

Enable Spindle Relay & select Clockwise (M3) Output#1

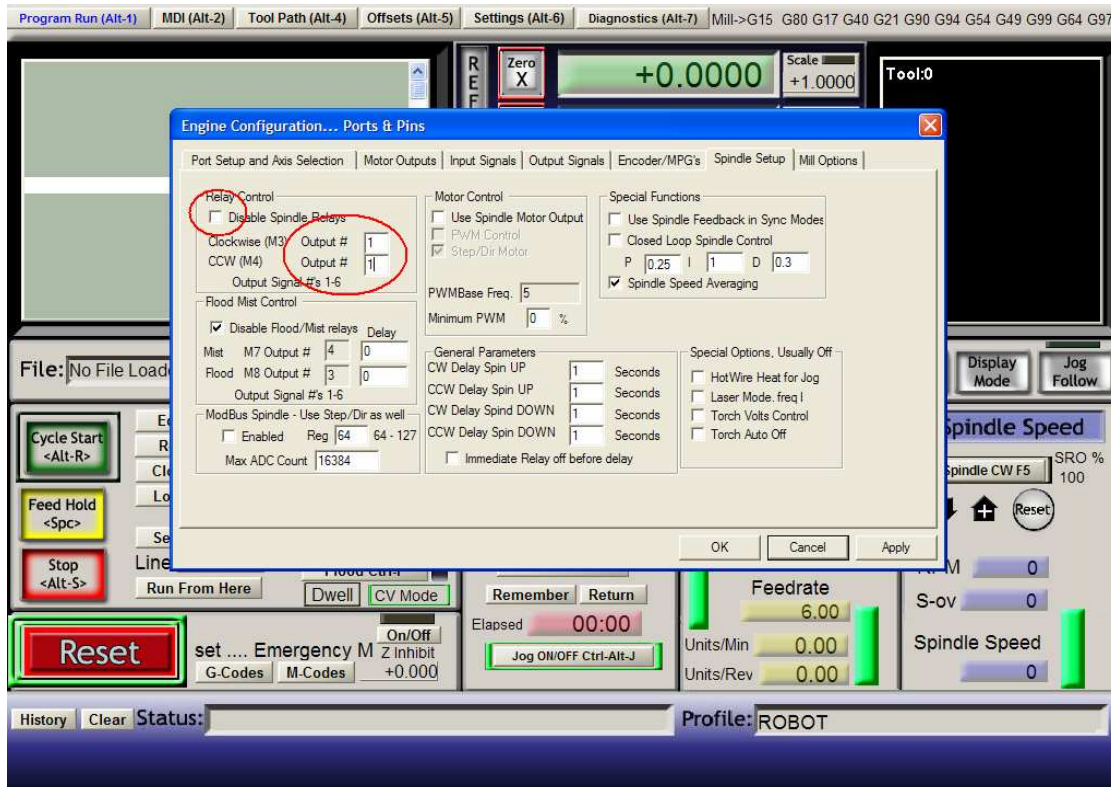

Limit setting & Home X,Y,Z Pin10, 11,12

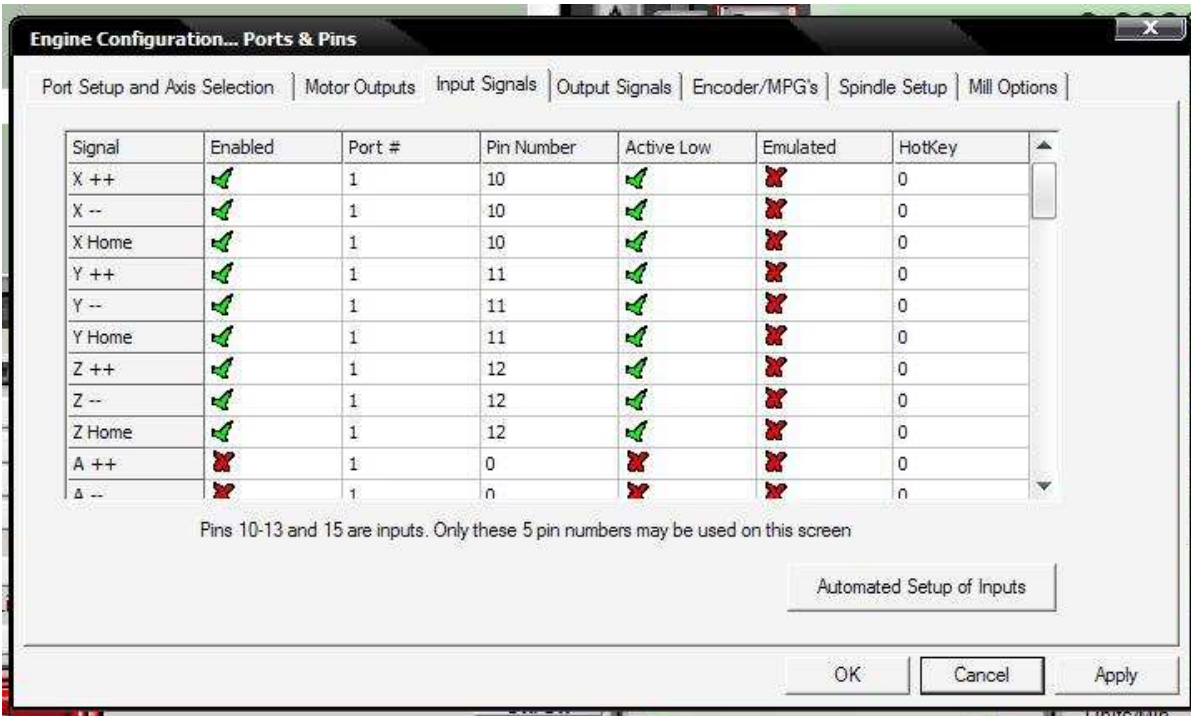

E-stop Pin 13

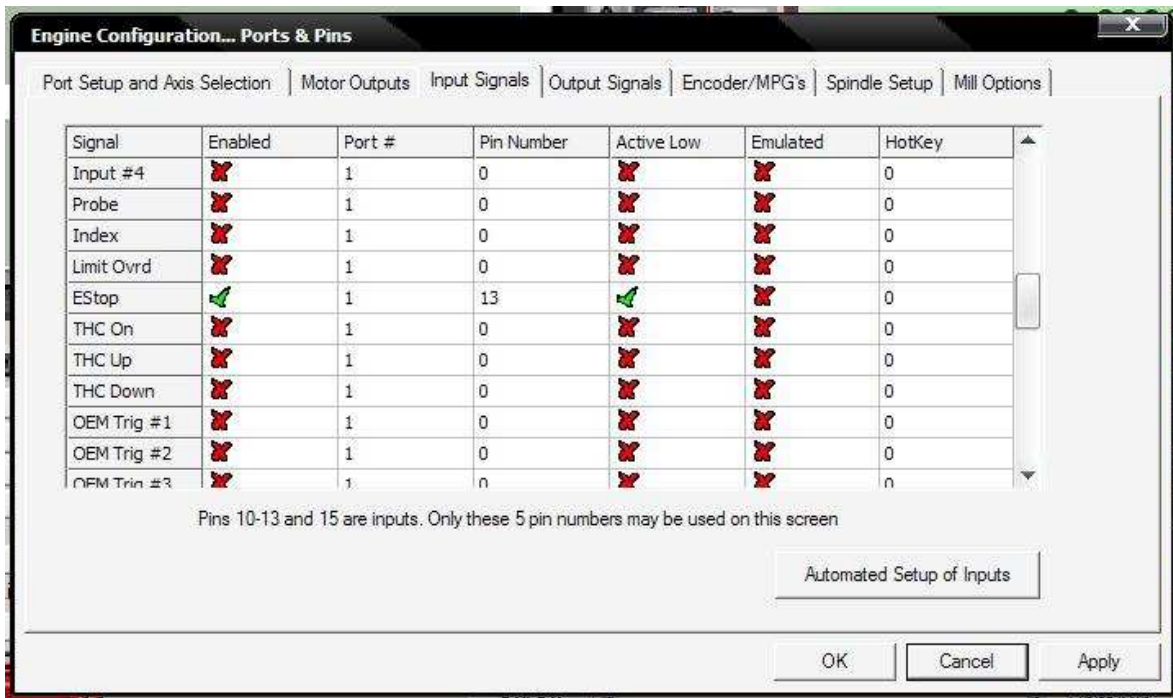

Limit setting & Home X,Y,Z,A Pin 10,11,12



DB 9 Connection

Pin 1	10	Limit+,- & Home X	Connect witch Ground (G)
Pin 2	11	Limit +,- & Home Y	Connect witch Ground(G)
Pin 3	12	Limit +,- & Home Z	Connect witch Ground(G)
Pin 4	13	E-Stop	Connect witch Ground(G)
Pin 5-9		Ground	

Use Auto Setup Of Input Signals

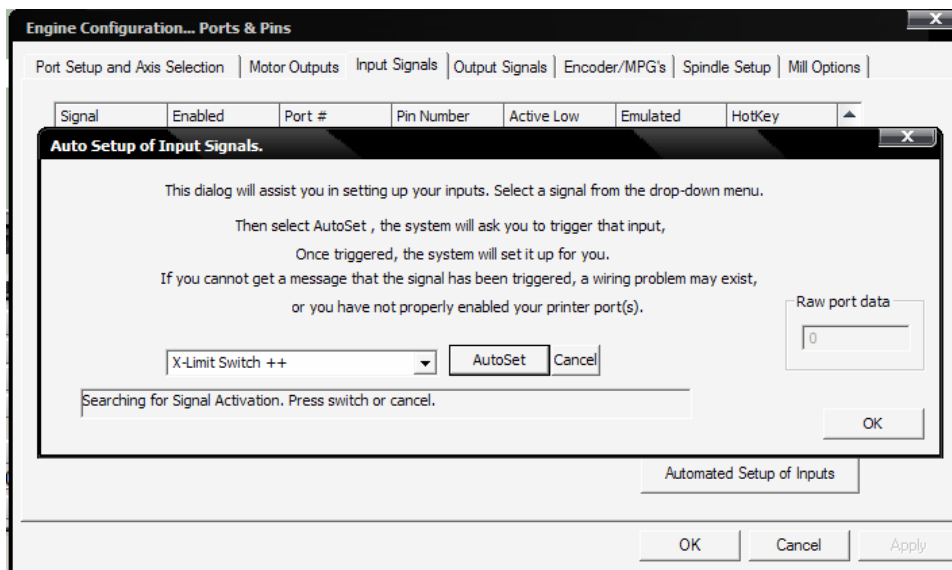

The definition of output Interface:

P1	P2	P3	P4	P5	P6	P7	P8	P9	P10	P11	P12	P13	P14	P15	P16	P17
VDD	GND	XB-	XB+	XA-	XA+	YB-	YB+	YA-	YA+	ZB-	ZB+	ZA-	ZA+	CB-	CB+	CA-
P18	P19	P20	P21	P22												
CA+	Rela y NO	G	G	Rela y NC												

