

User Guide for 3 axis TB6560 driver board

เป็นสินค้าจากประเทศจีน ที่มีจุดเด่นของ DRIVER BOARD ของ Toshiba TB6560AHQ chip ตามรายละเอียด

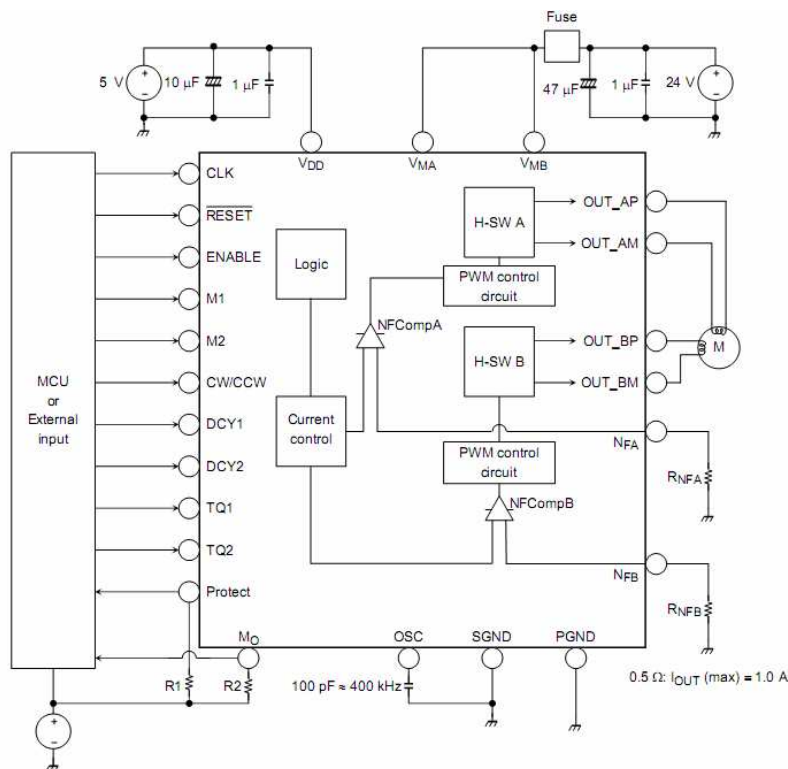

Block Diagram Toshiba TB6560AHQ chip

Product Features:

1. **Toshiba TB6560AHQ chip** - High power, maximum 3A (peak value 3.5A) drive current chipset !
2. **Micorstep** 1-1/16 micro step setting - Higher accuracy and smoother operation than standard 1, 1/2 step!
3. **current settings** Adjustable drive current settings for each axis - 25%,50%,75%,100% of full current can be set for different stepper motors
4. **Overload** over-current and over-temperature safety - Full protection for your computer and peripheral equipment !
5. **On board current switching** - Power output can be set according to specific user requirement !
6. **Full closed-type optical isolation** to protect the user's computer and equipment
7. **Relay spindle interface-Outputs** Max. 36V 7.5A for spindle motors or coolant pump (only one device can be powered by this output!)
8. **4channel inputs interface** Can be used for XYZ limit and emergency stop !(Input 1,2,3,4)
9. **Professional design** Two stage signal processing with super anti-jamming !
10. **Bipolar constant current** chopper drive with non-resonant region - Controls motors smoothly through range without creep effect !
11. **Universal architecture** Supports most parallel software MACH3,KCAM4,EMC2 etc!

* Important Notes:

Power supply DC 12-36V (not included)

*Voltage Selection:

12-16V DC power supply for Nema 17 stepper motors
 16-24V DC power supply for Nema 23 stepper motors
 24-36V DC power supply for Nema 34 stepper motors
 (High voltage will burn up the chips or stepper motors!!!)

***Ampertage Selection:**

Output current of the power supply can be calculated by the following expressions:

Output current = Rated current of your stepper motors * quantity + 2A

(For example, if you want to drive 3 * 3A Nema 23 stepper motors, theoretically 24V 11A DC power supply is recommended, but higher power such as 24V 15A also will be good.

If you are not sure about the selection of power supply, please feel free to contact us for help)

The power output of 12V shall be applied to the radiator fan of 12V

Driver output compatible with 2 or 4 phase, 4,6 or 8 lead stepper motors, 3A max.

Voltage regulated spindle speed controlled by parallel interface as function of supply voltage.

Wiring Diagram:

The diagram shows five wiring configurations for stepper motors:

- 4 Lead coils:** A bipolar configuration with terminals A+, A-, B+, and B-.
- 6 Leads High Torque:** A bipolar configuration with terminals A+, NC, A-, B+, NC, and B-.
- 6 Lead High Speed:** A bipolar configuration with terminals A+, A-, NC, B+, B-, and NC.
- 8 Leads Series - wound High Torque:** A bipolar configuration with terminals +A, -A, +B, and -B.
- 8 Leads Shunt - wound High Speed:** A bipolar configuration with terminals +A, -A, +B, and -B.

Below the diagrams is a graph of TORQUE vs SPEED. The graph shows three curves: BIPOLAR SERIES, BIPOLAR PARALLEL, and UNIPOLAR & HALF COIL. The BIPOLAR PARALLEL curve shows the highest torque at low speeds, while the UNIPOLAR & HALF COIL curve shows the highest torque at high speeds.

Serial & parallel Wiring Diagram For select Speed & Torque

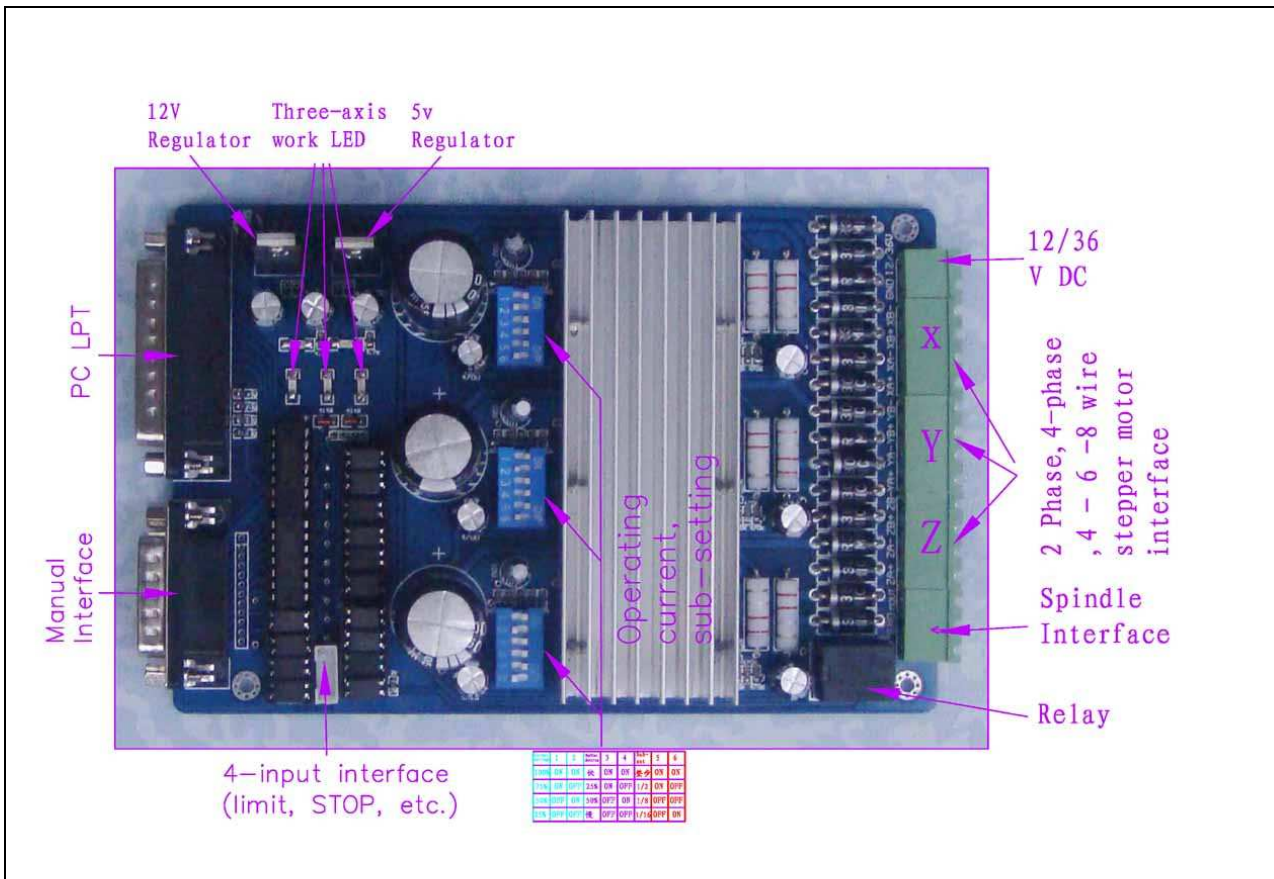

Dip settings:

Current Setting	1	2	Decay Mode Settings	3	4	MicroStep Settings	5	6
100%	ON	ON	FAST	ON	ON	1	ON	ON
75%	ON	OFF	25%	ON	OFF	1/2	ON	OFF
50%	OFF	ON	50%	OFF	ON	1/8	OFF	OFF
25%	OFF	OFF	SLOW	OFF	OFF	1/16	OFF	ON

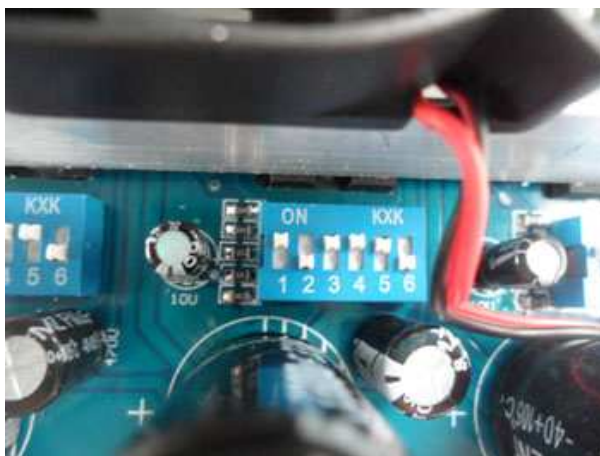

Dip Switch

The definition of 1-PIN 25 of Parallel Interface:

PIN 9	PIN14	PIN7	PIN1	PIN2	PIN3	PIN8	PIN6	PIN4	PIN5	PIN16	PIN17
spindle motor	X Enable	X Dir	X Step	Y Enable	Y Dir	Y Step	Z Enable	Z Dir	Z Step	Expand output 1	Expand output2

The definition of 4 channel inputs interface:

PIN 13	PIN 10	PIN 11	PIN 12
Input1 (E-STOP)	Input2(Limit&Home X)	Input3(Limit&Home Y)	Input4(Limit&Home Z)

The definition of 1-PIN15 of Manual Interface:

P1	P2	P3	P4	P5	P6	P7	P8	P9	P10	P11	P12	P13	P14	P15
X Step	X Enable	Spindle Motor	X Dir	Y Enable	Z Dir	Z Step	Z Enable	Y Limit	Z Limit	Y Dir	Y Step	STOP	GND	5v/VDD

Configuration Output Step & Dir X,Y ,Z

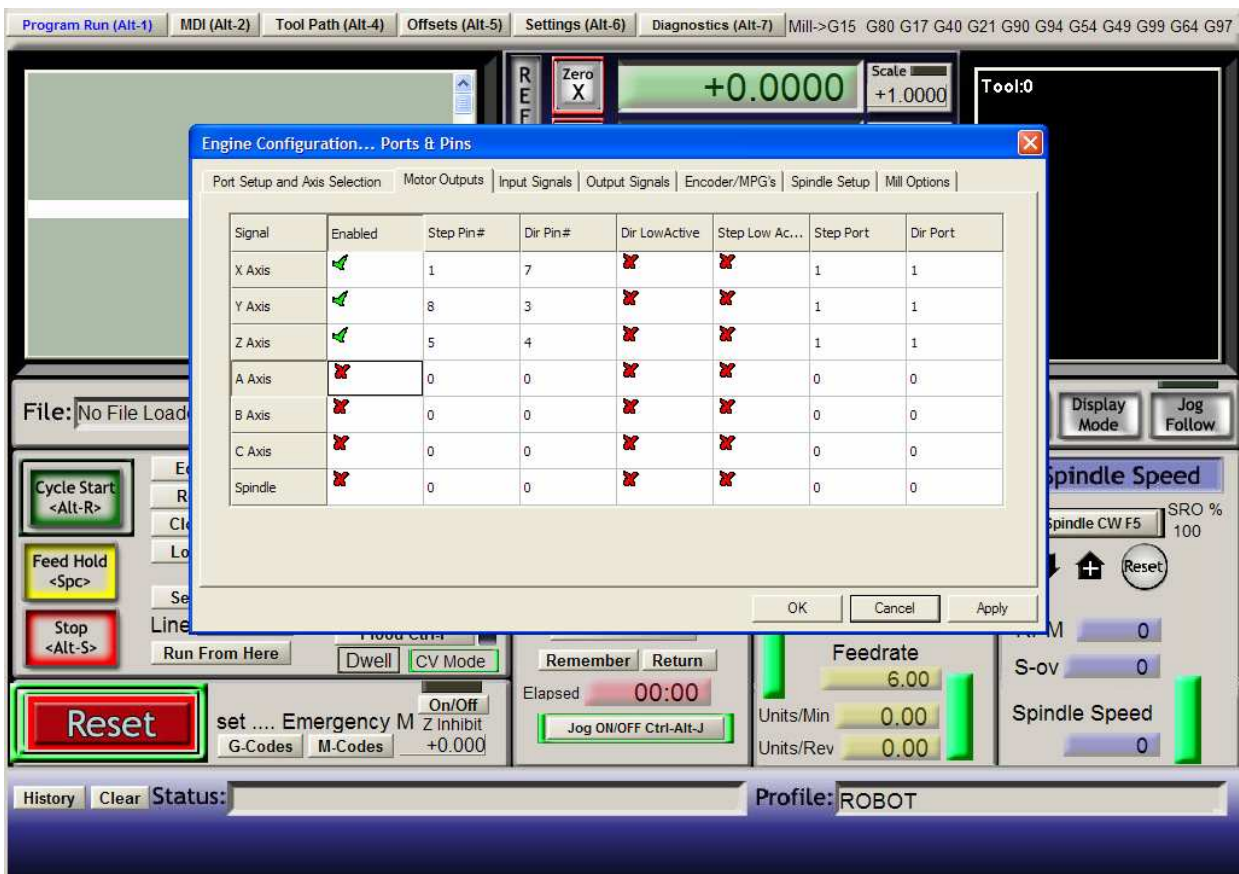

Configuration Output Enable 1-3(X,Y ,Z) pin 14,2,6 & Output#1 pin 9 For Spindle Motor (M3)

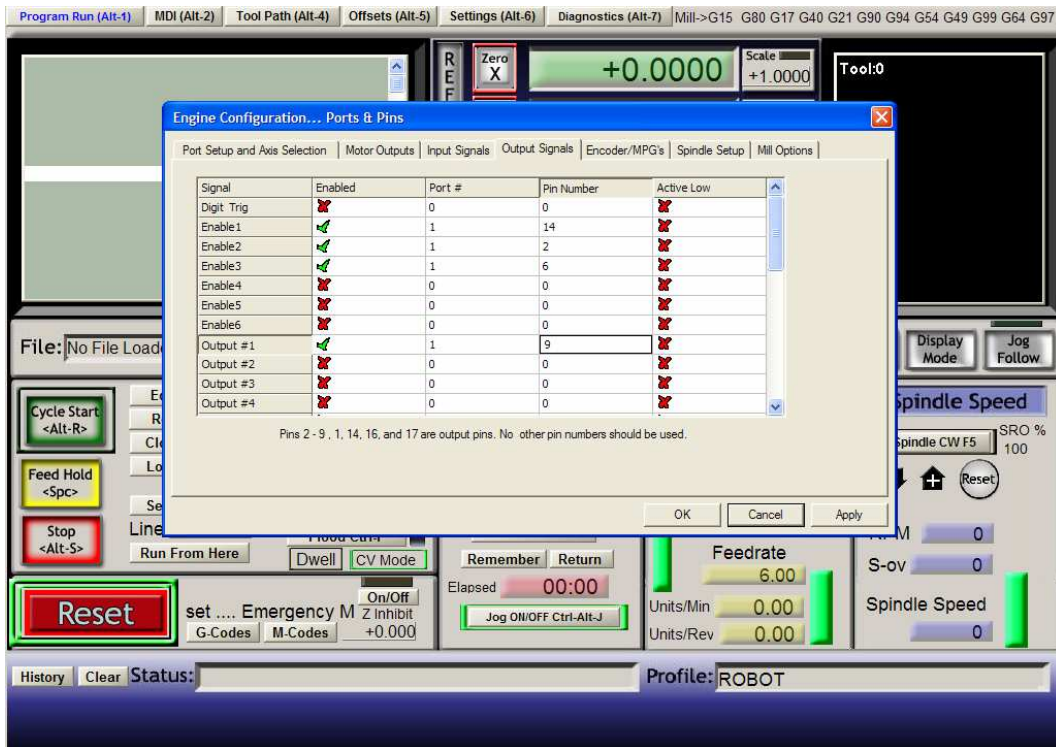

Enable Spindle Relay & select Clockwise (M3) Output#1

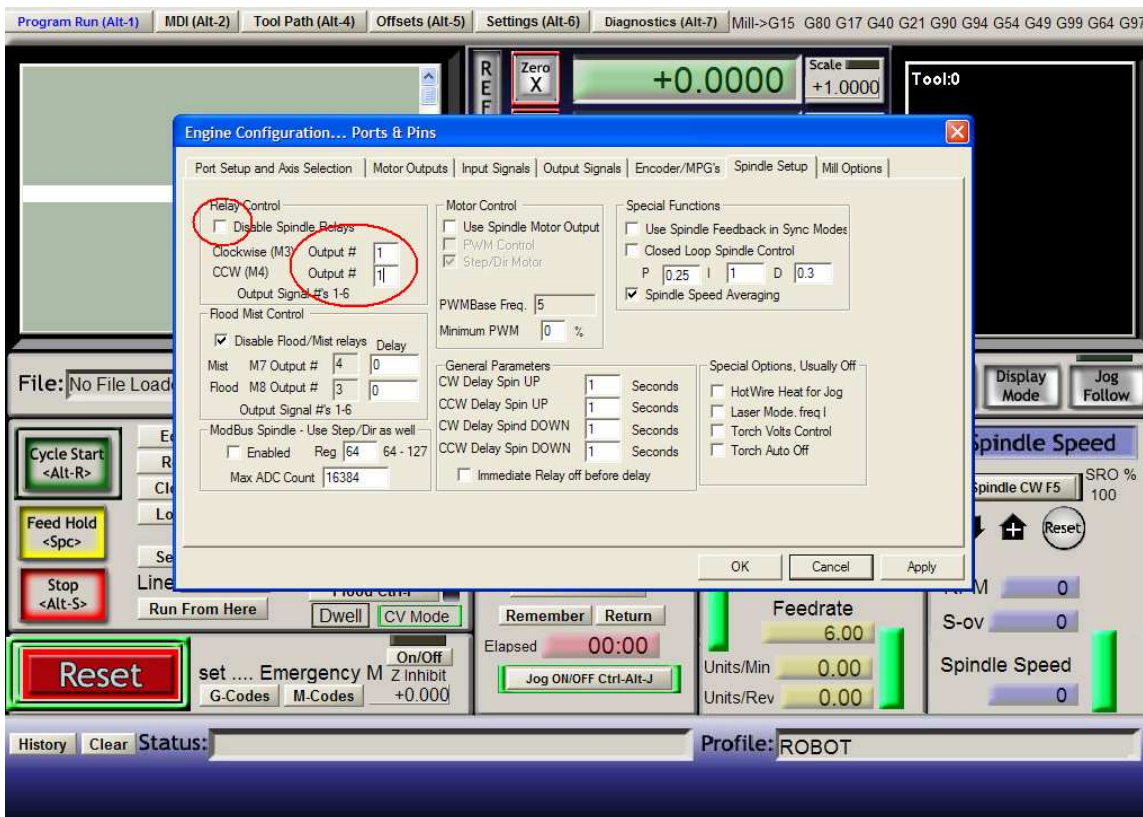

Limit setting & Home X,Y,Z Pin10, 11,12

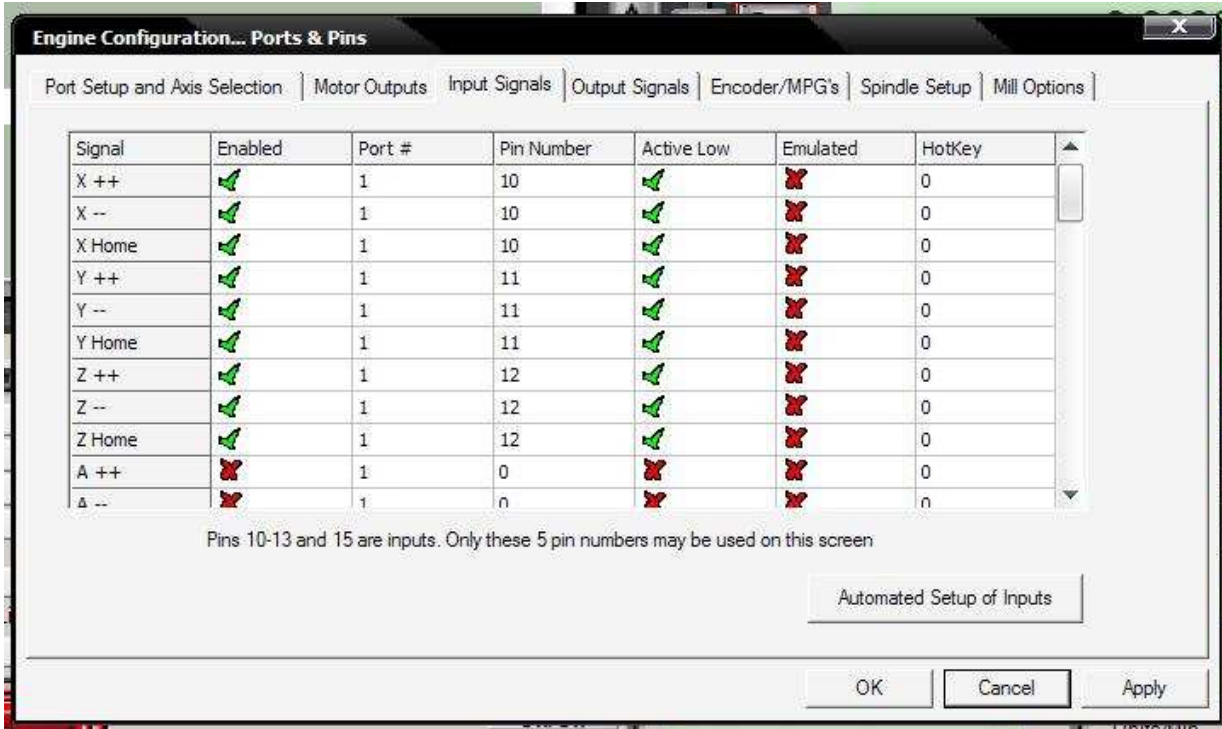

E-stop Pin 13

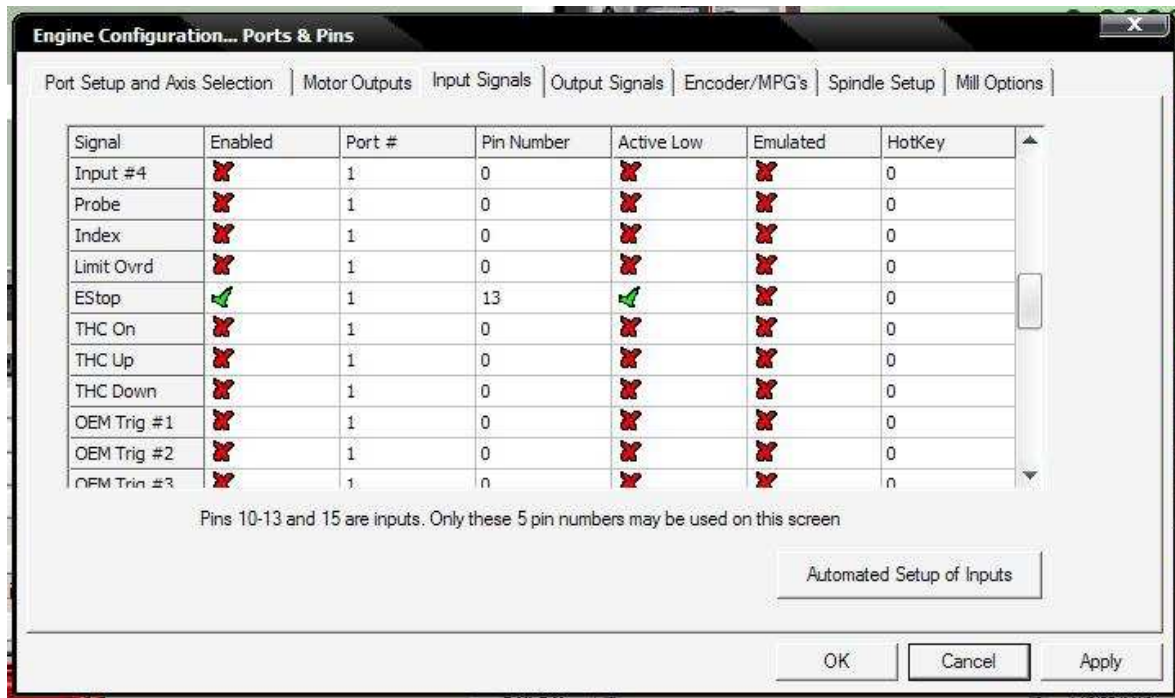

Limit setting & Home X,Y,Z Pin 11,12,13

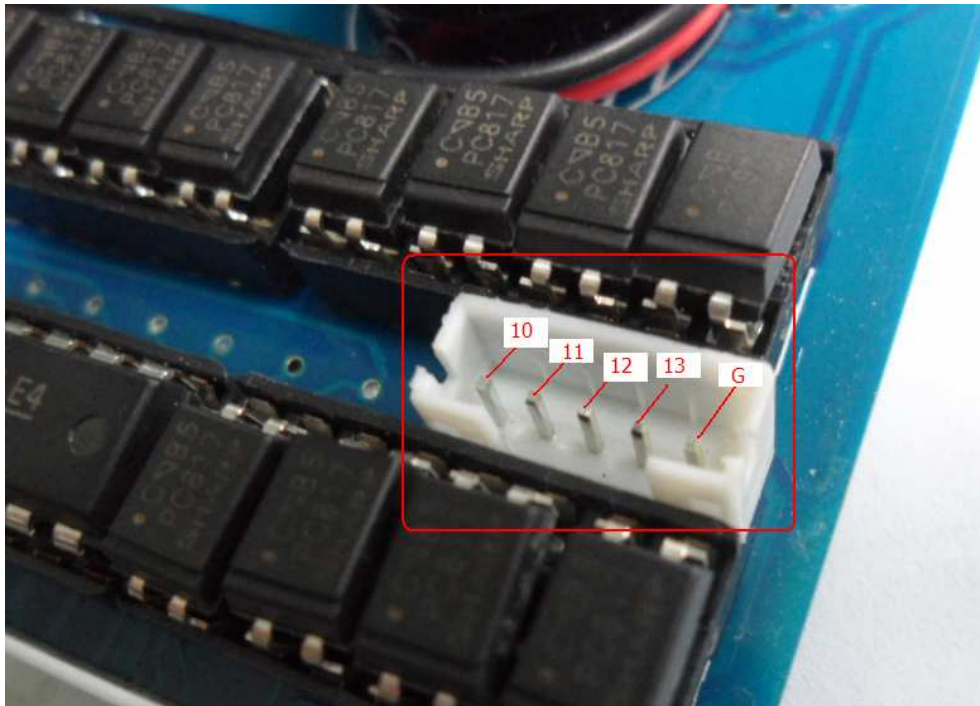

- Pin 10 Limit+,- & Home X Connect with Ground (G)
 Pin 11 Limit +,- & Home Y Connect with Ground(G)
 Pin 12 Limit +,- & Home Z Connect with Ground(G)
 Pin 13 E-Stop Connect with Ground(G)

Use Auto Setup Of Input Signals

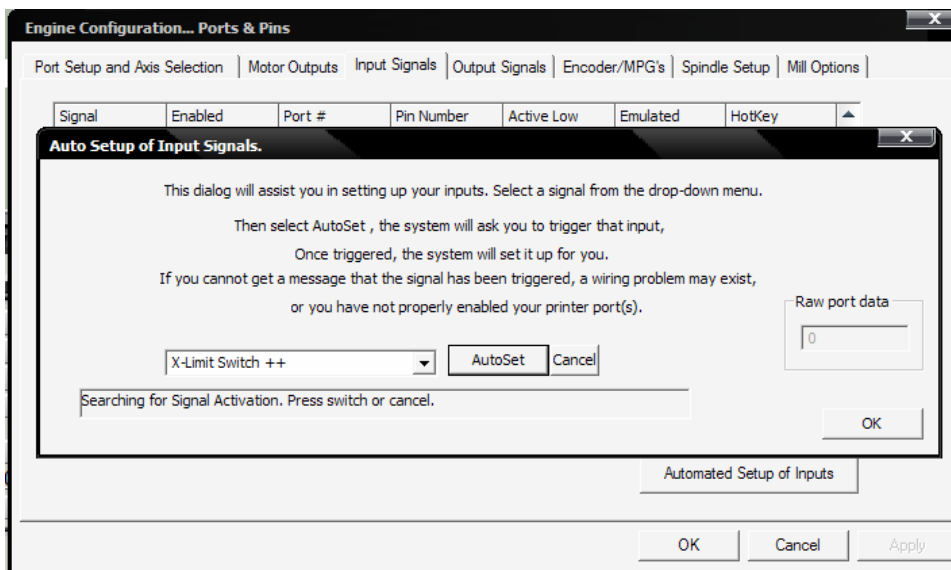

The definition of output Interface:

Pin1	Pin2	Pin3	Pin4	Pin5	Pin6	Pin7	Pin8	Pin9	Pin10	Pin11	Pin12	Pin13	Pin14	Pin15	Pin16	Pin17
VDD	G	XB-	XB+	XA-	XA+	YB-	YB+	YA-	YA+	ZB-	ZB+	ZA-	ZA-	Lela yNO	G	Lela yNc

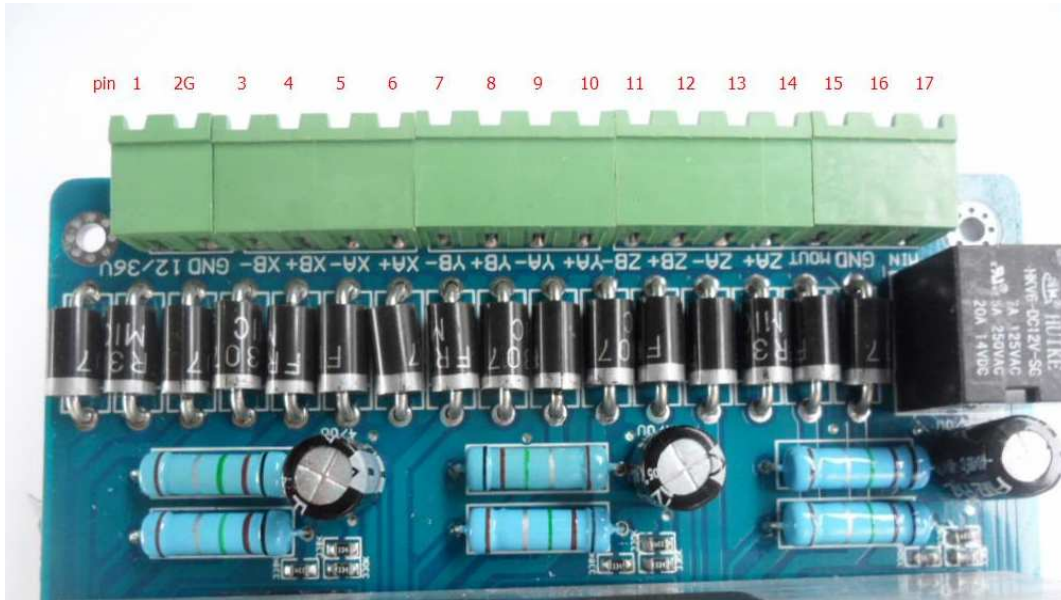

Output pin 16 ,17

